

MARBON INC



MARBON

INCORPORATED

CAST STONE PRODUCTS

INTRODUCTION

Cast stone provides flexibility in form, contour and texture of classic and contemporary architectural design features. These features include, but are not limited to:

Columns and Pilasters
Mouldings
Balustrade Systems
Wall Caps
Piers and Pier Caps
Stair Tread and Risers
Pool & Spa Copings
Window Sills
Flatwork
Pavers
Vertical Wall Veneer
Quoins
Medallions
Finial Treatments
Fireplaces
Ornaments
Decorative Frieze Panels

Many of the Cast stone products can be manufactured in straight and radius form, as well as well as various colors and textures.

The purpose of this catalog is to introduce our standard line of classic and contemporary cast stone products in order to assist you to achieve your architectural design requirements.

About Us

Marbon Stone Designs Cast Stone Products

Marbon Stone Designs is a well established full service cast stone company located in Palm Beach County, Florida. We are one of the most active and successful cast stone distributors in all of Florida and we have been creating and installing quality cast stone as well as natural stone throughout Palm Beach, and surrounding counties for more than a decade.

Marbon Stone Designs is a distributor of a wide variety of products including fireplaces, columns, balustrade systems, wall and pier cap, spa & pool copings, deck pavers, stair treads, as well as brackets/corbels, moldings, ornaments and custom architectural components. The meticulous work of our experienced installers consistently exceeds customer expectation.



The Marbon Stone Designs Executive Team

Paul Vassalotti

Mr. Vassalotti is a professional mason with over 50 years experience working alongside his father and brothers, a true Italian family tradition. He owned and operated his own successful masonry company for more than 45 years and possesses an invaluable understanding of what it takes to fully complete projects.

Brad Vassalotti

Brad has been working in the cast stone industry since 2004. A graduate of FAU, he comes from a large family of masons as far back as his great-great grandfather. In 2007 he established Marbon Stone Designs. He is a proficient auto cad designer and also assists clients in architectural designs. Some of Brad's completed projects can be seen at Disney Springs, Universal Studios and Seaworld. He has worked on the Marriot Hotel in Naples, Florida, numerous mansions in Palm Beach, with values of up to fourteen million dollars as well as historical renovations including The Society of the Four Arts of Palm Beach.

Paul and Brad Vassalotti have helped design many projects for contractors, architects, designers and homeowners. Their knowledge and understanding of cast stone designing, manufacturing and installation has made Marbon Stone Designs a leader in the cast stone industry.

Contact Paul or Brad Vassalotti at:

Marbon Stone Design, Inc.

8259 North Military Trail #F

Palm Beach Gardens, Florida 33410

561-727-8377

[Contact Us](#)

[\(Edit\)](#)

MARBON, INCORPORATED

CAST STONE PRODUCTS

COLORS AND TEXTURES

KEYSTONE -

Marbon Cast Stone replicates the natural "porous" coral limestone that has been quarried historically in the South Florida Region. The standard quarry texture is available in a wide range of fifteen standard colors.* This random pattern texturing may easily be varied from light, to our standard, or to heavy by request, at no additional charge.

UNTEXTURED -

This non-textured finish is available in the same standard colors as "KEYSTONE"

- Color Sample Boxes are available upon request.
- Some products are not currently available in all of these textures and finishes. Please consult your Marbon Inc. representative.

STANDARD CAST STONE

1. RAW MATERIALS:

- a. White Portland Cement-ASTM C150-TYPE I
- b. Silica Aggregate-ASTM C897-88
- c. Limestone Aggregate-ASTM C903
- d. Limestone Aggregate-ASTM C897-89
- e. Oxide Pigment (sufficient to achieve desired coloration).
- f. Potable Water (sufficient to achieve proper adhesion of ingredients and workable consistency).

2. BATCHING:

Mechanical agitation consistent with standard industry practices and procedures.

3. PLACEMENT:

Manual

4. SHIPMENT:

- a. Palletized
- b. Banded
- c. Poly-Wrapped

5. ADDITIONAL DATA:

Copies of D.O.T./ASTM testing requirements and /or certifications available upon request.

PRODUCT DATA

- The product data sheet denotes the basic raw materials in cast stone products manufactured by Marbon, Inc.
- Although decorative, the same high quality raw materials required for structural components are utilized.
- Admixes often are included, consistent with standard industry practices and procedures.
- As standard practice with many of our products, fiber reinforcement is added when required or specified.

G.F.R.C.

GLASS FIBER RE-INFORCED CONCRETE is a "light-weight" manufacturing process that Marbon, Inc., utilizes in many products. Although it includes a "proprietary formulation", the raw materials are also of the same high quality.

Contract Agreement: Terms and Conditions of Sale

Quotation: All quantities, sizes, textures, colors and designs must be verified, approved and accepted by the owner/contractor; no other areas or materials will be included. This must be done in writing. No verbal orders will be accepted. If Marbon Inc. standard profiles are not used these items must be noted and shop drawings provided.

Deposit: Each account is required to pay a *non-refundable* deposit prior to manufacturing.

Manufacturing: Materials will take approximately 4-6 weeks to manufacture from stock molds. Fabrication of radius or custom molds will take longer. The manufacturing of materials will not proceed until the following are received: signed quotation, signed Terms and Conditions, deposit check, copy of Notice of Commencement and field verified templates.

Measurements: It is the responsibility of the owner's/contractor's project manager to inform Marbon, Inc. when field measurements may be taken-i.e.: windows and doors installed, corner bead for stucco, grade established, steps/arches formed, poured and stripped, etc. This must be done in order to fabricate special size molds or radius molds for the specified product.

Additional Material: A signed quotation/purchase order for additional materials is required prior to any additional materials being manufactured. Such extras shall be treated as a new project with standard scheduling procedures.

Design Changes: If project conditions require altering materials for non-standard installation procedures or custom design, the owner/contractor must sign a work directive form instructing Marbon Inc. on how they intend for us to proceed. If additional cost or shop drawings are required for the work directive, a signed quotation/purchase order will be required from the owner/contractor prior to the work being performed. After material is altered, if the owner/contractor does not accept the final design concept, then the owner/contractor will be responsible for any additional cost to manufacture additional materials, shop drawings, and design changes.

Debris: All work is custom ordered, therefore we are regrettably unable to credit your account or accept returned materials, we do not restock material. Extra materials made for each project due to breakage, waste, and standard mold sizes will also not be credited. Cast stone debris to be removed by others.

Installation: All surfaces must be acceptable to Marbon Inc. before installation. The material is attached using thin set and tap cons, therefore, the backing must be within 1/4" tolerance. Any surface needing rework must be done at no expense to Marbon Inc. Protection of landscape, floors, walls, etc. to be done by others; Marbon Inc. will in no way be responsible for the damage of such items. In areas where columns & cast stone abuts wood or drywall surfaces, or those over an unstable surface, the joints may crack. Marbon Inc. will not be responsible for re-grout in these areas. Surfaces for installation of flatwork shall be within a 1/2" tolerance and slopped for drainage.

Lost or stolen: Materials that are lost or stolen or those items damaged by others at project site which need to be replaced will be billed for material and delivery charges to your account.

Deliveries: Deliveries will be designated for each order. If you request additional deliveries, you will be charged accordingly. The owner/contractor is to supply access for cast stone deliveries where materials are to be installed. Marbon Inc. will in no way be responsible for any damage to curbs, walks, driveways, streets or other areas.

Warranty: The warranty period is one (1) year from the substantial completion by Marbon Inc.

Stains: Staining caused by naturally occurring chemical impurities in the raw material, rust, landscaping, or from water runoff are not the responsibility of Marbon Inc., and are to be removed by others.

Sealant: Sealing of cast stone is an after market procedure and is not included in this agreement, if owner/contractor desires sealing we recommend that a qualified professional be obtained.

Back Charges: No back charges will be charged to Marbon Inc. without a certified letter detailing the reason for such charges. It is agreed that if Marbon Inc. feels that the back charge is legitimate then the owner/contractor must give Marbon Inc. (3) three working days to correct such condition to avoid such back charges.

Cancellations: If the project is cancelled for any reason, the owner/contractor is responsible for any or all cost for materials and/or labor completed.

Payment: All sales are due and payable within 30 days of the date of invoice. Owner/contractor agrees to pay interest at 1 1/2 % per month on past due amounts. If it becomes necessary to enforce payment (even if settlement is subsequently made before any court action becomes final) the owner/contractor also agrees to pay reasonable attorney fees (including attorney fees for appeal) and court costs.

Attorney's Fees: In the event Marbon Inc. initiates or defends litigation between Marbon Inc. and owner/contractor to enforce or defend its rights herein, the owner/contractor agrees to pay all costs in connection with such litigation as well as the reasonable attorney's fees of Marbon Inc.

Resolution of Disputes: Both parties must agree that the venue for any disputes arising out of this contract shall be Palm Beach County, Florida. If any conflicts exist in the Agreement between terms that are printed and those that are typed or written, the typed or written language shall govern. This Agreement shall be binding and their successors and assigns. The representation, warranties and indemnifications contained herein shall survive the termination of this Agreement.

Owner/contractor warrants there are no errors, omissions, or ambiguities in the quotation/terms and conditions other than any it has already brought to the attention of Marbon Inc. in writing and acknowledges any such items it has brought to the attention of Marbon Inc. were resolved to its satisfaction in these quotations/terms and conditions.

Marbon Inc. Representative

Date:

Owner/Contractor

Date :

TRADE REFERENCES : CONTRACTORS

Anderson Moore Const. Corp.
1568 Watertower Road
Lake Park, FL 33403
561-753-7400

Arvida
PO Box 100
7900 Glades Road
Boca Raton, FL 33429
561-473-1100

Browning & Becker
3460 Fairlane Farms Road, #6
Wellington, FL 33414
561-790-3224

Butler Construction
4807 Georgia Avenue
West Palm Beach, FL 33405
561-832-9700

Catalfumo Construction Ltd.
4300 Catalfumo Way
Palm Beach Gardens, FL 33410
561-624-9697

Centex Homes
8198 Jog Road, Suite 200
Boynton Beach, FL 33437
561-536-1042

C.W. Hayes Construction Co.
PO Box 621294
Oviedo, FL 32762
407-366-1564

First Florida Development
200 NE Dixie Highway
Stuart, FL 34994
772-692-1387

Hawkins Construction
PO Box 1636
Tarpon Springs, FL 34688
727-938-9719

Holt-Lee Construction
216 South Military Trail
Deerfield, FL 33442
954-725-4881

Kaufman Lynn Const. Co.
622 Banyan Trail, Suite 300
Boca Raton, FL 33431
561-361-6700

Leighton McGinn
1983 PGA Blvd., Suite 104
Palm Beach Gardens, FL 33408
561-863-4455

O'Connor & Taylor
8380 Resource Drive, #1
West Palm Beach, FL 33404
561-863-7349

Overland Construction
PO Box 767
West Palm Beach, FL 33402
561-683-3210

Proctor Construction Co.
1401 Highway A1A, #301
Vero Beach, FL 32963
772-234-8164

Republic Construction & Dev.
2100 Corporate Drive
Boynton Beach, FL 33426
561-572-3000

Proctor Construction Co.
1401 Highway A1A, #301
Vero Beach, FL 32963
772-234-8164

Republic Construction & Dev.
2100 Corporate Drive
Boynton Beach, FL 33426
561-572-3000

Scott Thomas Construction
201 Packets Court
Williamsburg, VA 23185
757-564-3455

Serraes Construction
1300 53rd Street
West Palm Beach, FL 33407
561-848-6607

Shakman Construction
2595 NW Boca Raton Blvd.
Boca Raton, FL 33431
561-750-8288

Sisca Construction
1280 N. Congress Ave., Ste 101
West Palm Beach, FL 33409
561-686-5459

The Weitz Company
1720 Centrepark Drive East
West Palm Beach, FL 33401
561-686-5511

W. G. Yates & Sons
PO Box 456
Philadelphia, MS 39350
228-386-4324

TRADE REFERENCES: BUILDERS

Arthur Rutenburg Homes
AR Martin Homes, LLC
2300 SE Monterey Rd, Ste 101
Stuart, FL 34996
772-288-5021

BHD
631 U.S. Highway 1, Suite 100
North Palm Beach, FL 33408
561-840-4747

Casto Homes, Inc.
13842 US Highway 1
Jupiter, FL 33408
561-626-3444

Frankel Estate Homes
1200 Clint Moore Road
Boca Raton, FL 33487
561-994-6443

G. Mustapick Companies, Inc.
14041 US Highway 1, Suite A
Juno Beach, FL 33408
561-626-2600

Jacoviello Custom Homes, Inc.
351 South US Hwy. 1, Ste. 105
Jupiter, FL 33471
561-746-5546

Kenco Communities
1000 Clint Moore Road, Ste 110
Boca Raton, FL 33487
561-997-5760

Hobgood Construction
2189 Radnor Ct.
North Palm Beach, FL 33408
561-691-9686

Linehan Builders Inc.
4723 125th Ave. South
Wellington, FL 33467
561-792-3999

Miller Custom Builder, Inc.
6775 Newport Lake Circle
Boca Raton, FL 33496
561-988-1075

National Custom Homes, Inc.
1181 S. Rogers Circle, #31
Boca Raton, FL 33487
561-988-1267

Paone Builders, Inc.
2151 S. Highway A1A, #425
Jupiter, FL 33477
561-575-0664

Prometheus Group, Inc.
2901 Clint Moore Road, #412
Boca Raton, FL 33496
561-477-1616

Rob Francis, Inc.
5551 Center Street
Jupiter, FL 33458
561-575-4811

Robelen & Assoc., Inc.
3518 Pinehaven Circle
Boca Raton, FL 33431
561-482-9999

Sabatello Const. of FL, Inc.
5610 PGA Blvd., #114
Palm Beach Gardens, FL 33418
561-626-7600

Spear Valencia Corp.
3721 SW 47th Ave., Suite 307
Fort Lauderdale, FL 33314
954-581-9000

Turtle Beach Const. Co., Inc.
103 S. US Highway 1, Ste A-5
Jupiter, FL 33477
561-741-1307

Vintage Properties
4205 W. Atlantic Ave., Ste 201
Delray Beach, FL 33445
561-496-7899

The Cury Group
324 Royal Palm Way, #204
Palm Beach, FL 33480
561-832-1600

Marbon, Incorporated

Trade References

DESIGNERS

The Decorators Unlimited
4700 Riverside Drive, Suite 100
Palm Beach Gardens, FL 33410
561-625-3000

The Decorators Unlimited
160 SW 12th Avenue, #107
Deerfield Beach, FL 33442
954-596-2613

Howards Interiors
3100 SE Federal Highway
Stuart, FL 34994
772-286-0221

Cheryl Glass Associates
1400 Longlea Terrace
Wellington, FL 33414
561-784-9990

Debra Juliano Interior Design
One South Ocean Blvd., Suite 207B
Boca Raton, FL 33432
561-368-6367

Rogers Design Group
7108 Fairway Drive
Palm Beach Gardens, FL 33410
561-799-2545

Wadsworth House
110 Boca Raton Road
Boca Raton, FL 33432
561-210-8109

MARBON Incorporated
CAST STONE PRODUCTS

PIER CAPS
STANDARD DESIGN FORMS

SECTION 3 * REVISED: JAN-2006 *

WALL CAPS and PIER CAPS

REVISIONS EFFECTIVE: Jan. 2006

Profile Designations for Wall Caps and Pier Caps have been revised. The improved system will simplify selections for corresponding or complimenting profiles. Many standard profiles remain, some with additional options, and others are entirely new.

The Revised Numbering System for both Wall Cap (WC) and Pier Cap (PC) Profiles range from: "11" through "27".

The first number will designate the top configuration: "1" for Flat Top; "2" for Peaked-Top. Refer to the Tables for the Peak (C) dimensions.

The second number will designate the "Profile" which will remain consistent whether the product is a Wall Cap or a Pier Cap; either "Flat Topped" or "Peaked Topped."

Refer to the Tables accompanying each Wall Cap or Pier Cap Profile. Standard Dimension Availabilities and Limitations are listed within. Also, corresponding Marbon Cast Stone Moulding Profiles are indicated.

As always, "Custom Profile" products are available at an additional charge.

WALL CAPS and PIER CAPS
REVISIONS EFFECTIVE: Jan. 2006

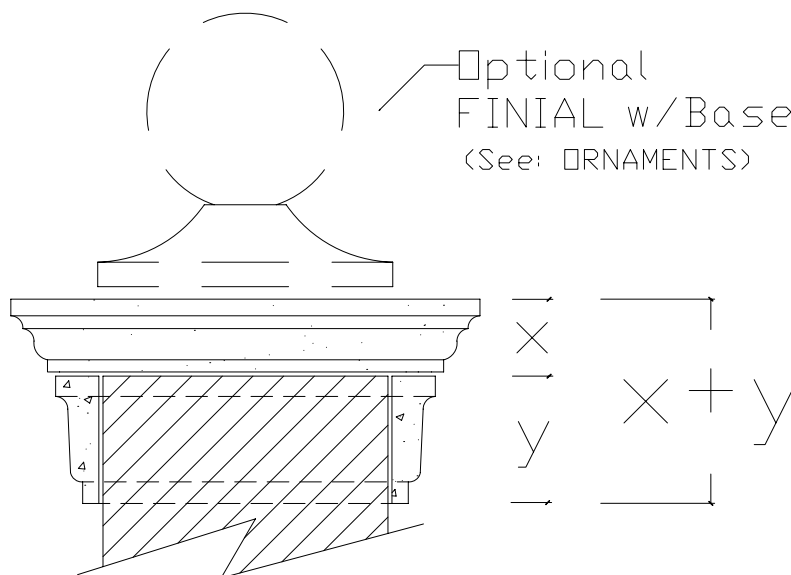

Wall Cap and Pier Cap Profiles (X)
may be enhanced by the placing
of an additional moulding (Y)
below the expanded cap.

MARBON Incorporated
 CAST STONE PRODUCTS

PIER CAPS
 STANDARD DESIGN FORMS

SECTION 3

* REVISED: JAN-2006 *

A	B
14" TO 26"	3/4"
14" TO 34"	1 1/2"
14" TO 50"	2 1/2"
14" TO 50"	3"

C
1/2" TO 3"

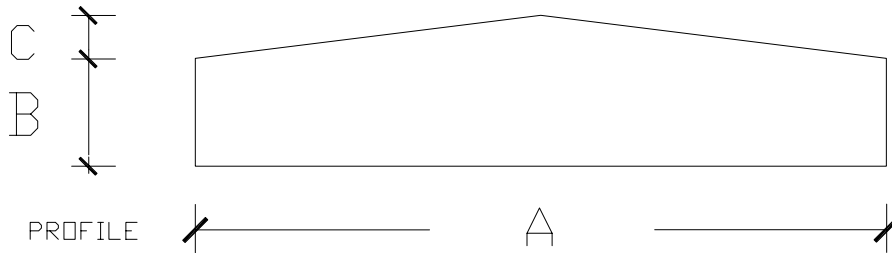
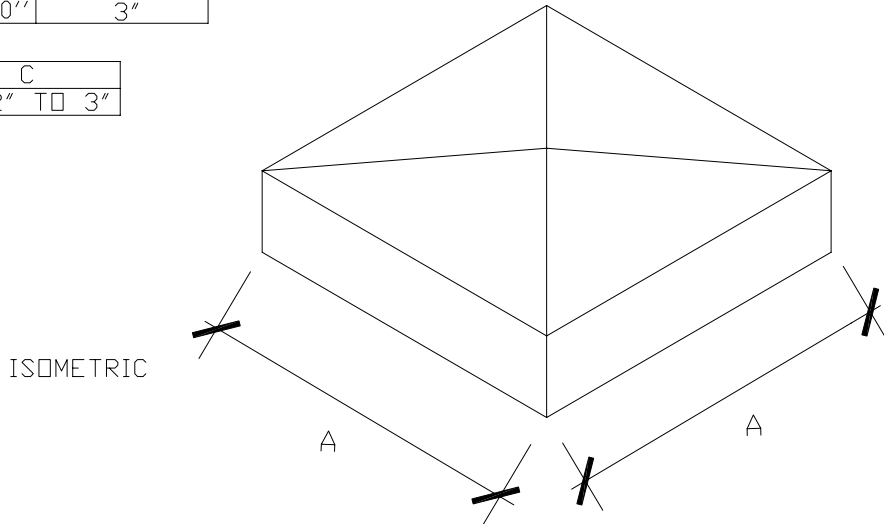

PC-20

PIER CAP

NTS

MARBON Incorporated
 CAST STONE PRODUCTS

PIER CAPS
 STANDARD DESIGN FORMS

SECTION 3

* REVISED: JAN-2006 *

A	B
18"	20"
26"	28"
34"	36"
50"	52"

ISOMETRIC

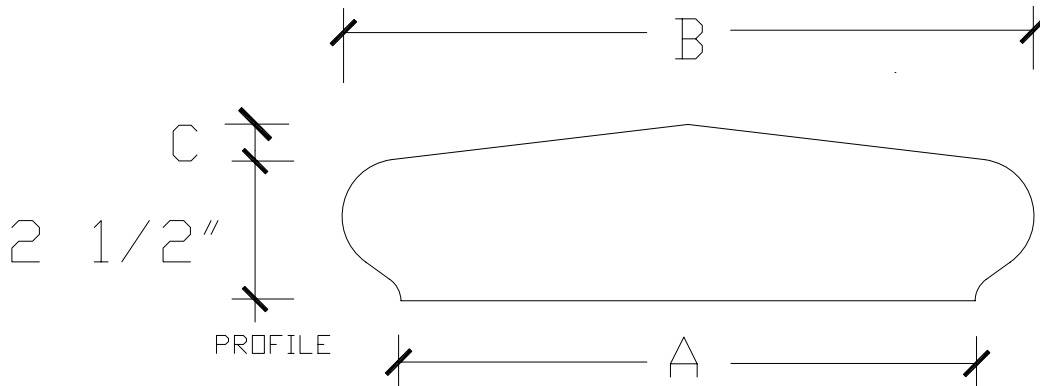
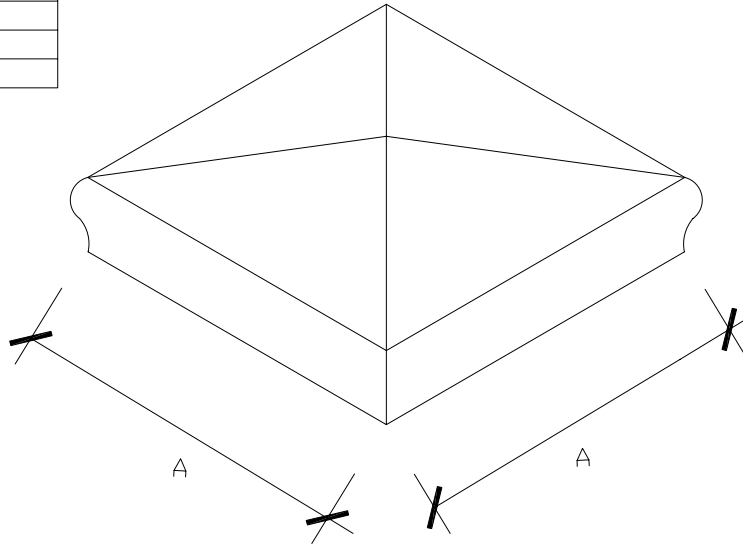

PC-21

PIER CAP

NTS

MATCHES: M-8

MARBON Incorporated
 CAST STONE PRODUCTS

PIER CAPS
 STANDARD DESIGN FORMS

SECTION 3 * REVISED: JAN-2006 *

A	B
18"	20"
26"	28"
34"	36"
50"	52"

ISOMETRIC

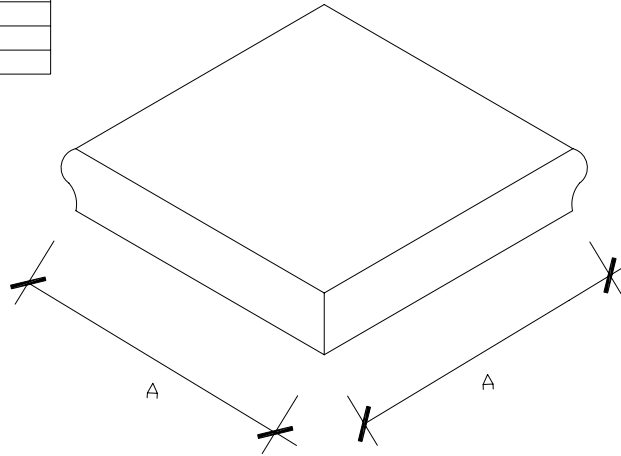

2 1/2"

PROFILE

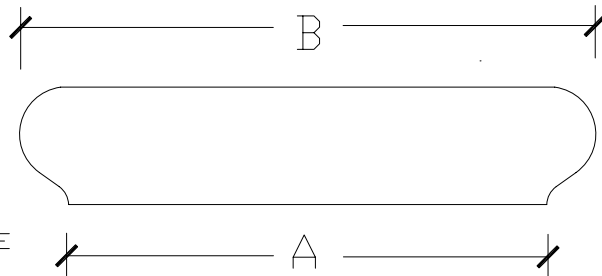

PC-11

PIER CAP

NTS

MATCHES: M-8

A	B
18"	21"
26"	29"
34"	37"
50"	53"

ISOMETRIC

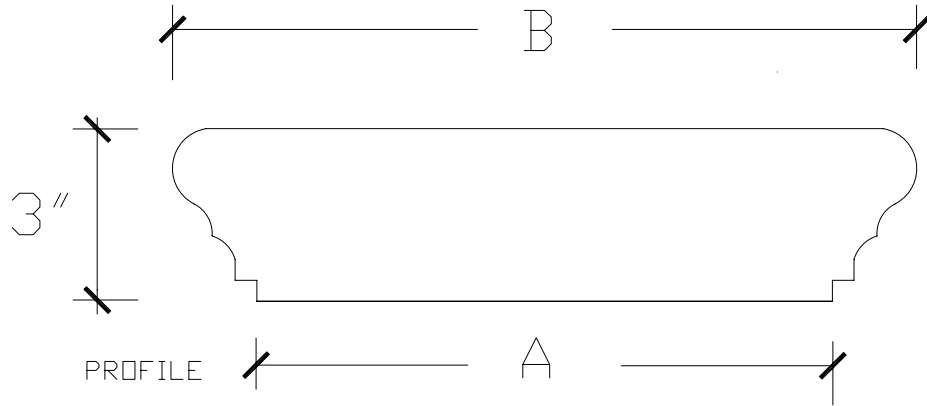
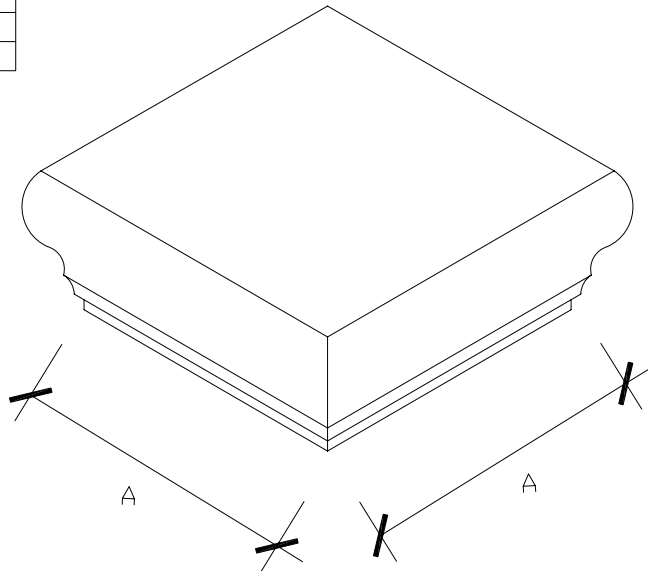

PC-12

PIER CAP

NTS

MARBON Incorporated
 CAST STONE PRODUCTS

PIER CAPS
 STANDARD DESIGN FORMS

SECTION 3 * REVISED: JAN-2006 *

A	B
18"	20"
26"	28"
34"	36"
50"	52"

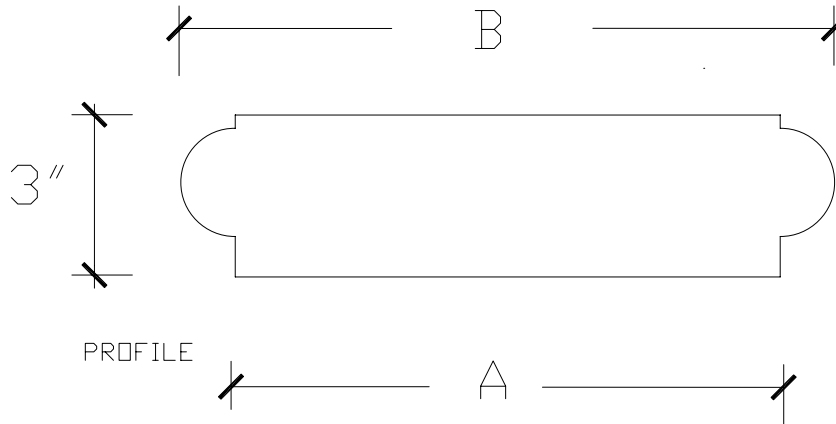
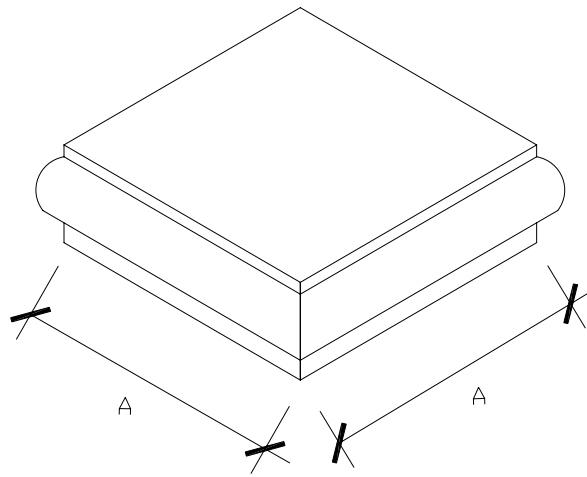

PC-13

PIER CAP NTS

MARBON Incorporated
 CAST STONE PRODUCTS

PIER CAPS
 STANDARD DESIGN FORMS
 SECTION 3 * REVISED: JAN-2006 *

A	B
18"	21"
26"	29"
34"	37"
50"	53"

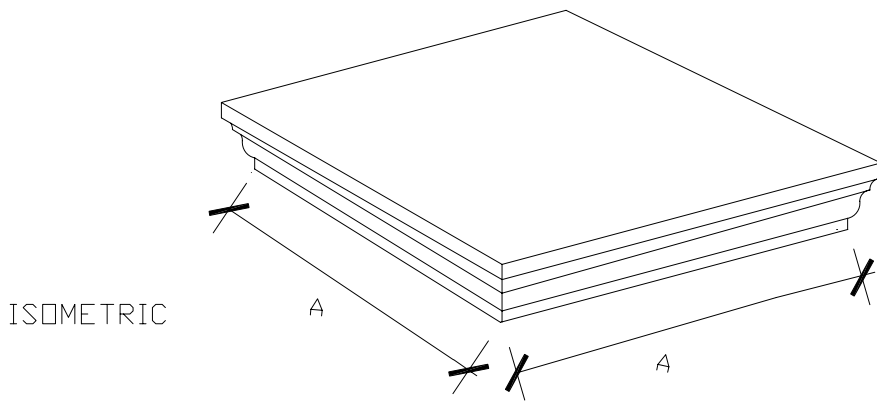

PC-16

PIER CAP

NTS

MATCHES: M-4

MARBON Incorporated
CAST STONE PRODUCTS

PIER CAPS
STANDARD DESIGN FORMS
SECTION 3 * REVISED: JAN-2006 *

A	B
18"	20"
26"	28"
34"	36"
50"	52"

C
1/2" TO 3"

ISOMETRIC

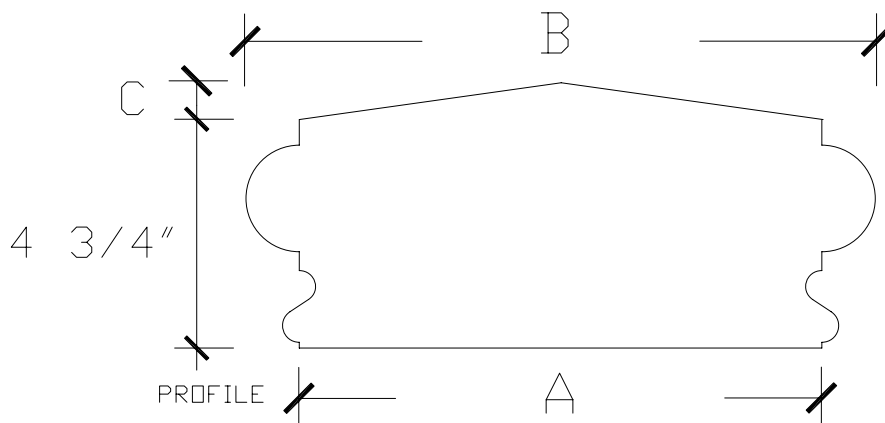
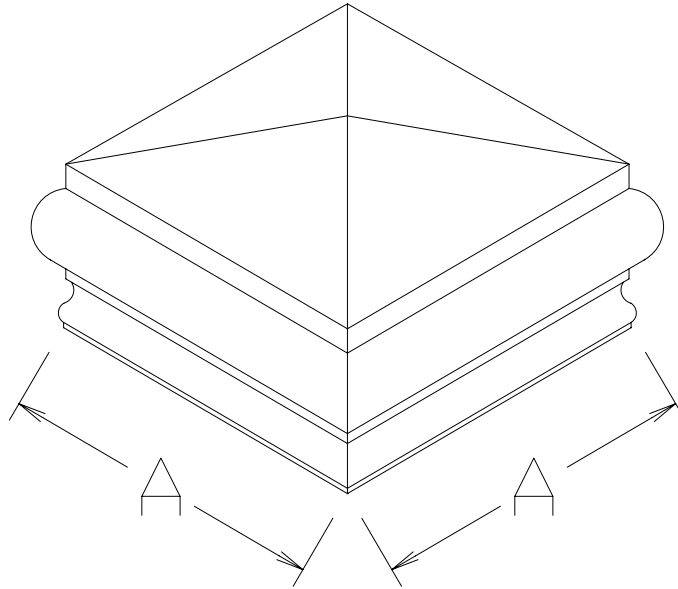

PC-26

PIER CAP

NTS

MARBON Incorporated
CAST STONE PRODUCTS

PIER CAPS
STANDARD DESIGN FORMS

SECTION 3 * REVISED: JAN-2006 *

A	B
18"	21 1/4"
26"	29 1/4"
34"	37 1/4"
50"	53 1/4"

ISOMETRIC

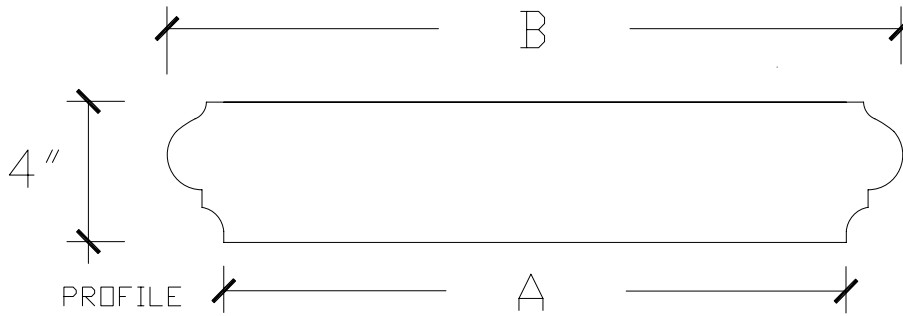
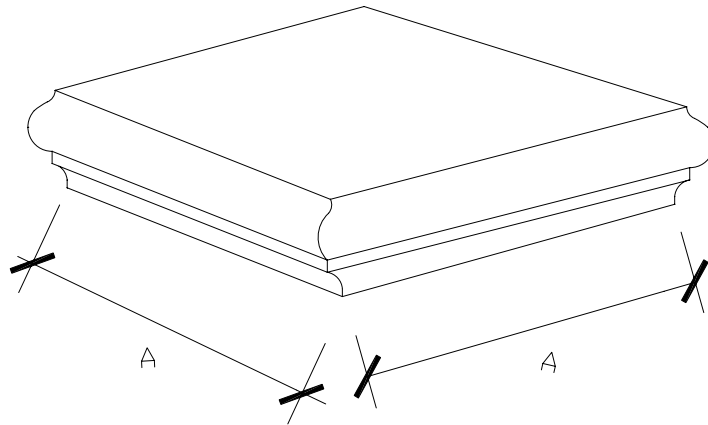

PC-15

WALL CAP

NTS

MATCHES: M-10/BC-4

MARBON Incorporated
 CAST STONE PRODUCTS

PIER CAPS
 STANDARD DESIGN FORMS
 SECTION 3 * REVISED: JAN-2006 *

A	B
18"	20"
26"	28"
34"	36"
50"	52"

ISOMETRIC

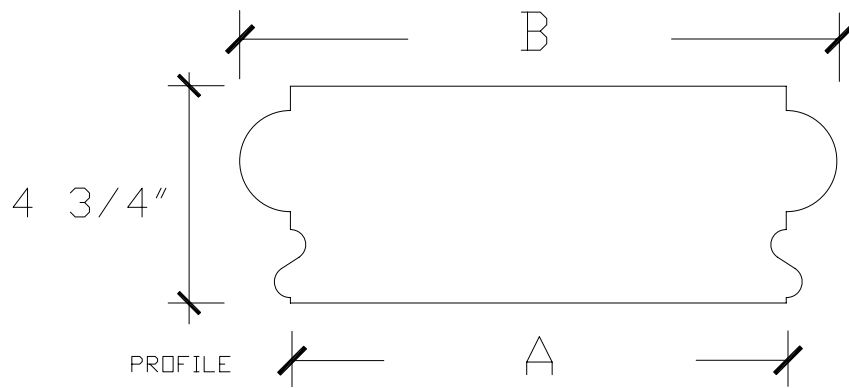
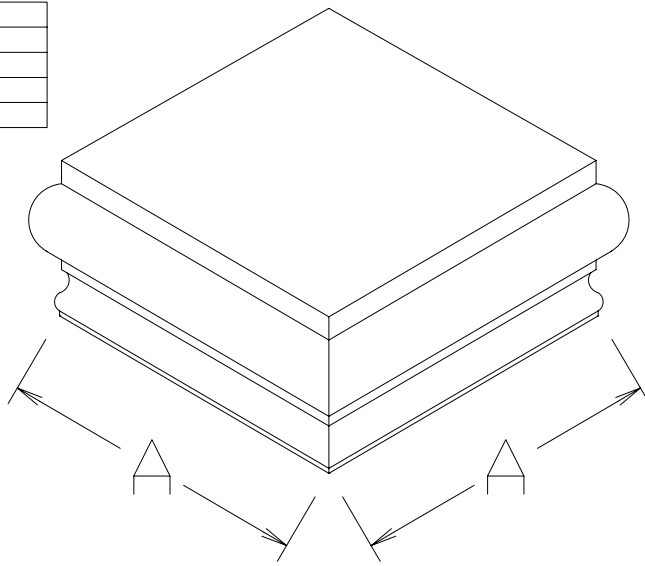

PC-16

PIER CAP

NTS

A	B
18"	26 1/2"
26"	34 1/2"
34"	42 1/2"
50"	58 1/2"

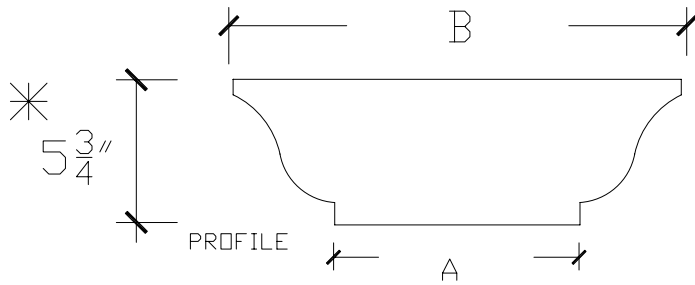
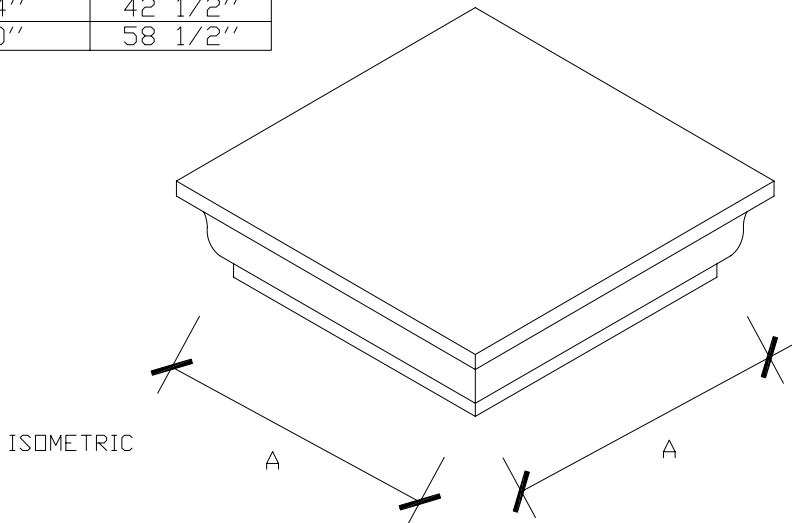

PC-17

PIER CAP

NTS

*MATCHES: M-32

MARBON Incorporated
 CAST STONE PRODUCTS

PIER CAPS
 STANDARD DESIGN FORMS

SECTION 3 * REVISED: JAN-2006 *

A	B
18"	21"
26"	29"
34"	37"
50"	53"

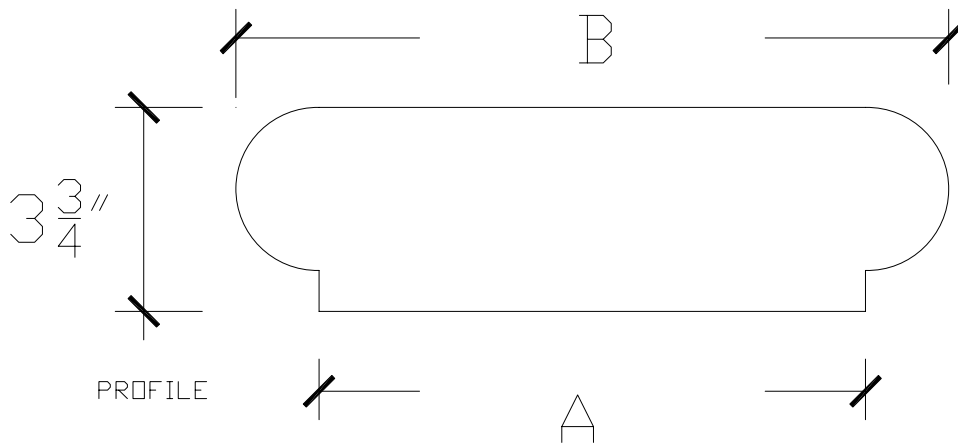
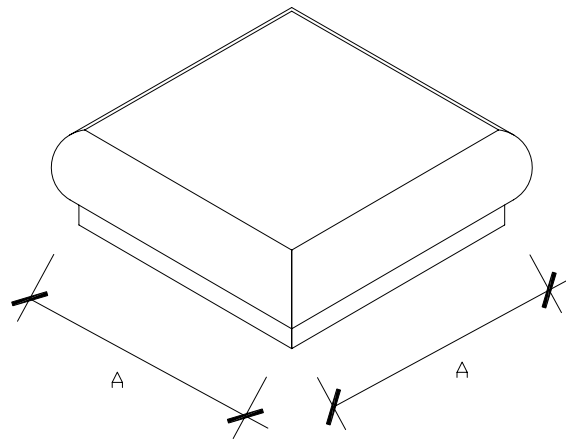

PC-18

PIER CAP

NTS

A	B
12" TO 50"	1 1/2"
12" TO 50"	2"
12" TO 50"	3"
12" TO 50"	4"

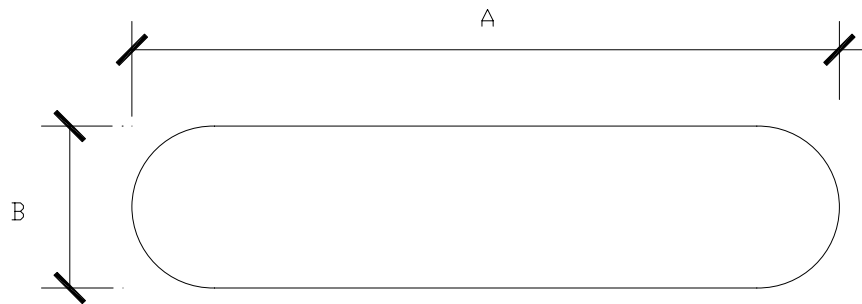
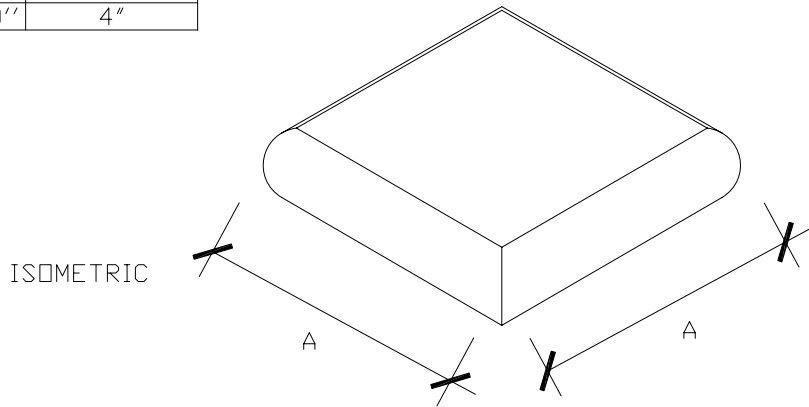

PROFILE

PC-19

PIER CAP

NTS

MARBON Incorporated
 CAST STONE PRODUCTS

PIER CAPS
 STANDARD DESIGN FORMS
 SECTION 3 * REVISED: JAN-2006 *

A	B
18"	21"
26"	29"
34"	37"
50"	53"

C
7/8" TO 3 3/8"

ISOMETRIC

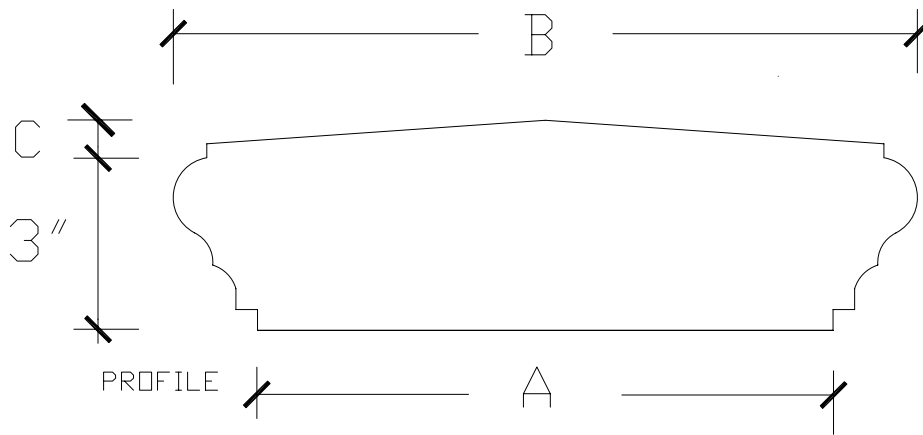
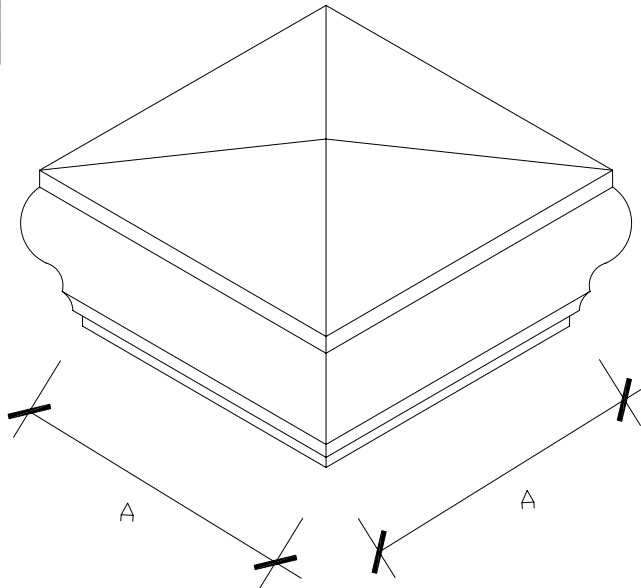

PC-22

PIER CAP NTS

MARBON Incorporated
CAST STONE PRODUCTS

PIER CAPS
STANDARD DESIGN FORMS

SECTION 3 * REVISED: JAN-2006 *

A	B
18"	20"
26"	28"
34"	36"
50"	52"

C
1/2" TO 3"

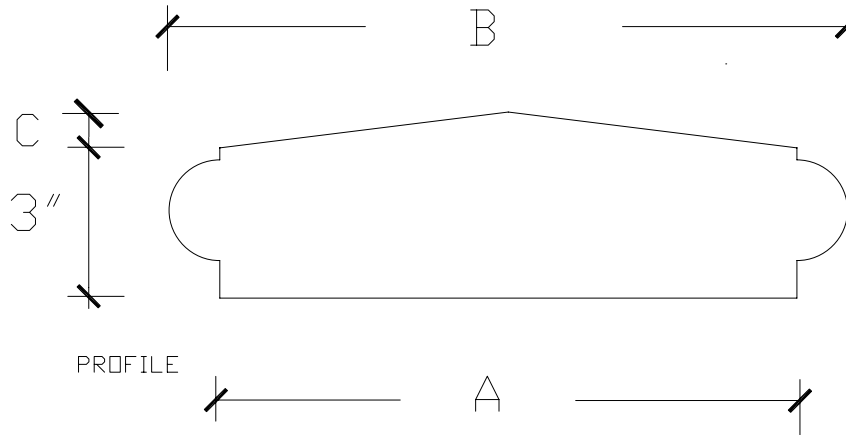
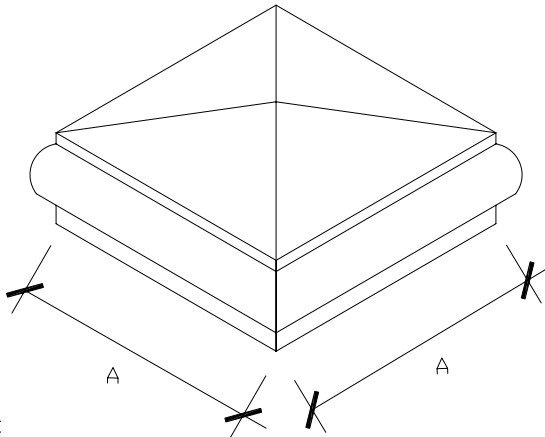

PC-23 PIER CAP NTS

MARBON Incorporated
CAST STONE PRODUCTS

PIER CAPS
STANDARD DESIGN FORMS

SECTION 3

* REVISED: JAN-2006 *

A	B
18"	21 1/4"
26"	29 1/4"
34"	37 1/4"
50"	53 1/4"

C
7/8" TO 3 3/8"

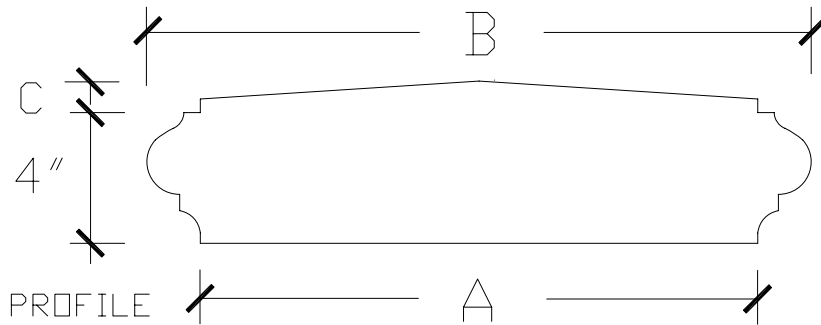
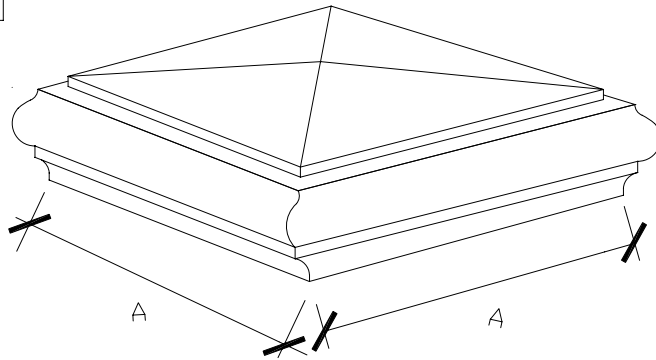

WC-25

WALL CAP

NTS

MATCHES: M-10

MARBON Incorporated
CAST STONE PRODUCTS

PIER CAPS
STANDARD DESIGN FORMS
SECTION 3 * REVISED: JAN-2006 *

A	B
18"	26 1/2"
26"	34 1/2"
34"	42 1/2"
50"	58 1/2"

C
1/2" TO 3"

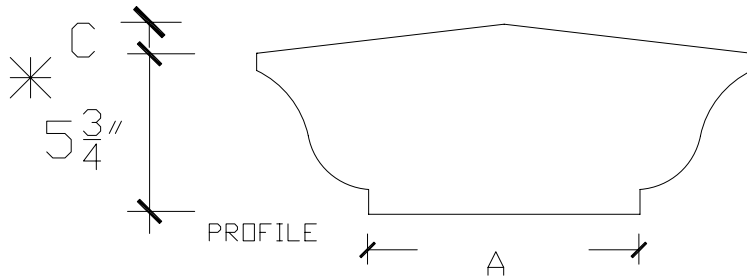
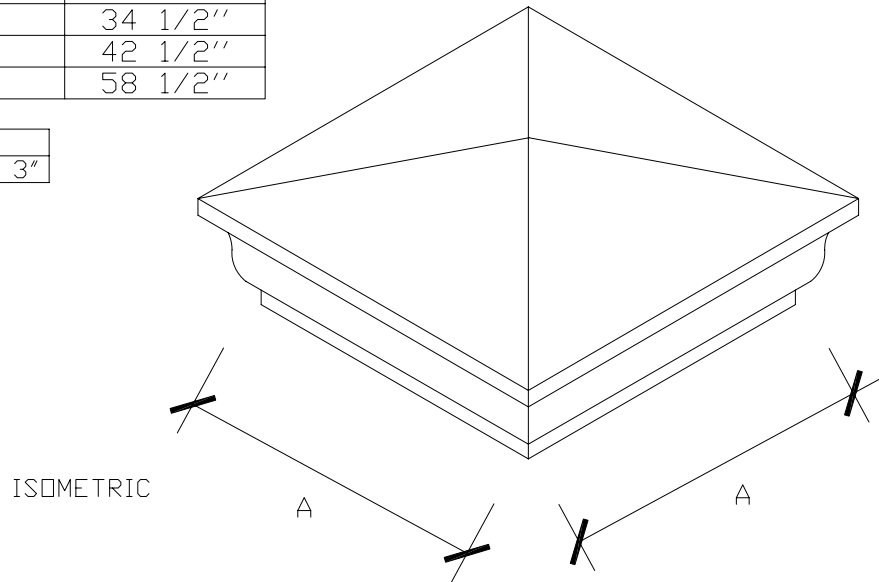

PC-27

PIER CAP

NTS

* MATCHES: M-32